

### DOT 406 and 407 Compliant

In August of 1995 the Department of Transportation (DOT) made several changes in the over-the-road tanker specification. Portions of the specification now cover aviation refuelers. DOT 406 and 407 require that all vents and pressure relief devices shall not leak more than one liter of product in the event of a rollover. Tanks used on aircraft refuelers, until recently, have not been able to comply. The main reason for the non-compliance was that the vents were outward opening vents, which were susceptible to opening when a positive head of fuel would be applied to the poppet in the event of a rollover.

Eaton's Carter product line offers Model 64168 3-inch Mechanically Operated Inward Opening Vent that is in compliance with DOT 406 and 407. In the event of a rollover, the more head pressure the poppet of the vent is subjected to, the greater the sealing capability.

Model 64168 is opened mechanically by a rod connected to the bottom loading valve (Eaton Bottom Loading Valve Models 64129, 64174 or equivalent).

### Features

- Full 3-inch flow capability
- Vapor hood — standard
- Fire screen — standard
- Buna N (nitrile) seals standard, Viton optional
- Fits standard 3-inch TTMA sump mounting ring

### Ordering Data

Model 64168 3-inch vent comes standard with a mounting flange to mate to a standard 3-inch TTMA sump ring, a fire screen and an aluminum vapor hood. The options shown below may be added to the basic 64168 model number to obtain desired features.

Option Letter	Description
A	Replaces standard hood with an aluminum hood to mate with OPW 5.375 inch (136.52 mm) dia. bolt circle with 6 holes .395 inch (10.03 mm) dia.
B	Replaces standard hood with 4-inch TTMA sump flange
D	Changes all seals from nitrile to Viton
E	Adjustable vent rod, aluminum tube to be provided by the customer

**Example:** 64168D — 3-inch vent with standard vapor hood, fire screen and Viton seals

## Envelope Dimensions

Shown in inches (millimeters)

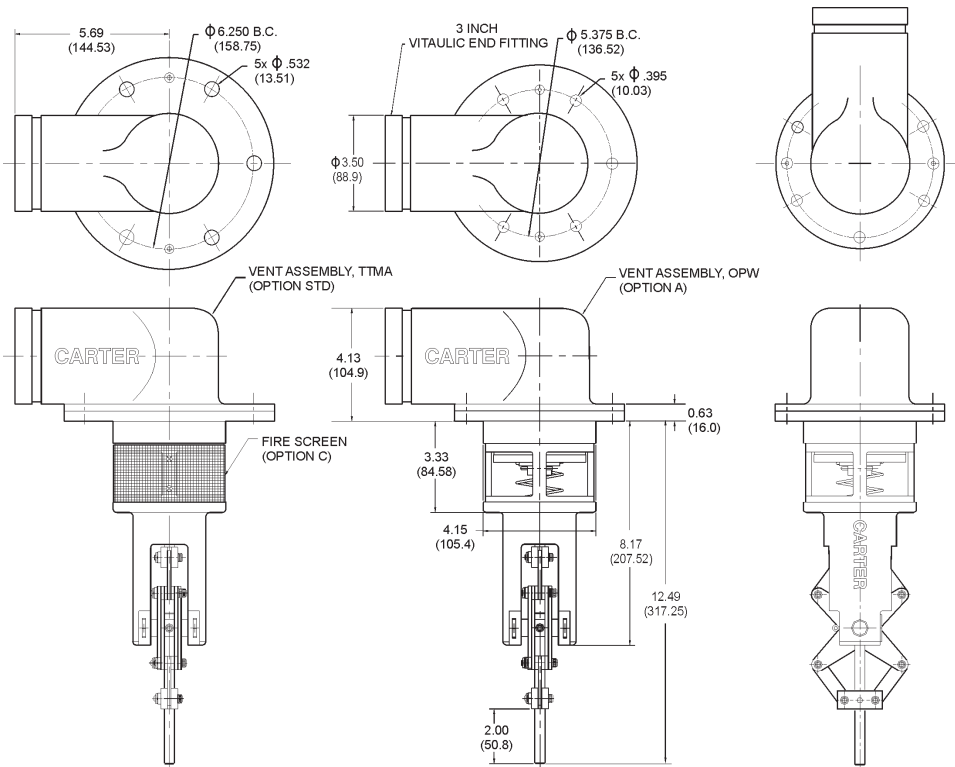

Eaton  
 Aerospace Group  
 Fuel & Electrical Distribution Division  
 9650 Jeronimo Road  
 Irvine, CA 92618  
 Phone: (949) 452 9500  
 Fax: (949) 452 9992  
 E-mail: [groundfueling@eaton.com](mailto:groundfueling@eaton.com)  
[www.eaton.com/aerospace](http://www.eaton.com/aerospace)

Copyright © 2013 Eaton  
 All Rights Reserved  
 Form No. DS100-104C  
 May 2013